

The Effects of SiC Particle Addition as Reinforcement in the weld Zone during Friction Stir Welding of Magnesium Alloy AZ31B

¹Md. Aleem Pasha, ²Dr. P. Ravinder Reddy, ³Dr. P. Laxminarayana, ⁴Dr. Ishtiaq Ahmad Khan

¹ Ph.D. Scholar, Mechanical Engineering Department, Osmania University, Hyderabad, India.

² Professor and HOD, Mechanical Engineering Department, CBIT, Hyderabad, India.

³ Professor, Mechanical Engineering Department, Osmania University, Hyderabad, India

⁴Project Manager, TATA Technologies, Pune, India.

DOI: <http://dx.doi.org/10.21013/jte.v3.n3.p6>

How to cite this paper:

Pasha, M., Reddy, D., Laxminarayana, D., & Ahmad Khan, D. (2016). The Effects of SiC Particle Addition as Reinforcement in the weld Zone during Friction Stir Welding of Magnesium Alloy AZ31B. *IRA-International Journal of Technology & Engineering (ISSN 2455-4480)*, 3(3). doi:<http://dx.doi.org/10.21013/jte.v3.n3.p6>

© Institute of Research Advances



This work is licensed under a [Creative Commons Attribution-Non Commercial 4.0 International License](https://creativecommons.org/licenses/by-nc/4.0/) subject to proper citation to the publication source of the work.

Disclaimer: The scholarly papers as reviewed and published by the Institute of Research Advances (IRA) are the views and opinions of their respective authors and are not the views or opinions of the IRA. The IRA disclaims of any harm or loss caused due to the published content to any party.

ABSTRACT

Welding of magnesium alloys influence a great effect on magnesium application expansion, especially in marine and aerospace where large-size, complex components are required. Due to specific physical properties of magnesium, its welding requires great control. In general, the solid-state nature of friction stir welding (FSW) process has been found to produce a low concentration of defects. Mechanical properties of friction stir welded joints are decreases than base material, so to enhance the mechanical properties of welded portion, In the present research additional SiC particulates were incorporated in the weld interface of friction stir welding of Magnesium alloy AZ31B. Silicon Carbide has been added as reinforcement by creating separate geometry, at the edges where the welding is interface with 4 different volume proportions such as 10%, 15%, 25% and 30%. Tool Steel of H13 grade has been used as friction stir welding tool. Rotational Speed of 1400 RPM and Transverse Speed of 25 mm/min were selected. Joined Mg Alloy AZ31B alloy plates were evaluated for their mechanical properties under two different conditions, i.e in the un-reinforced welded condition and reinforced welded conditions. The results of the study revealed that the mechanical properties of the SiC particulates added Mg alloy AZ31B welded joints are superior in all four proportions of SiC, compared to un-reinforced Mg alloy AZ31B welded joints. Microstructural examination of the welded joints was conducted using Optical microscope and revealed that distribution of SiC particles producing increased weld strength. The comparison of the microstructures and mechanical properties of unreinforced Friction stir welded AZ31 with those of SiC reinforced FS-welded joints showed that the addition of SiC particles decreased the grain size and increased the strength.

Key words: FSW, Mg alloy AZ31B, SiC reinforcement, Mechanical properties, Microstructures.

Introduction

Magnesium is the sixth most existing element on the Earth’s surface, with almost unlimited supplies in the oceans [1] Magnesium alloys and especially AZ31 represent unique structural materials combining low density and high specific strength with the capability to absorb shock and vibration energy [2]. AZ31 finds application in a wide variety of uses including aircraft fuselages, cell phone and laptop cases, speaker cones, concrete tools, and automotive components [3]. The principal drawbacks of Mg alloy as a structural material when fusion welded are residual stresses, metallurgical structure change, contamination, and porosity [4].

Friction stir welding is a solid-state welding process which uses friction as its main source to form welding. A rotating tool with a pin and a shoulder is longitudinally fed at a constant rate into a butt joint between two clamped pieces of material. The friction between the shoulder and the material produces enough heat to plasticize the material, and the pin helps move the plasticized material to form a strong bond between the materials to be joined [3]. Even though the joints made by FSW show better mechanical properties than the fusion-welded joints, research has been carried out to improve the different characteristics of these joints. Post weld heat treatment and change of chemical composition of the weld nugget are some of these attempts. Friction stir welding of AA7075 alloy with the addition of boron carbide (B4C) powder resulted in an improvement in the hardness of weld nugget, and it was attributed to the uniform distribution of strengthening precipitates in the matrix and particle strengthening. According to Huang et al. [8], AZ31 Mg alloy reinforced with SiC particles using friction stir processing revealed that the pinning effect of SiC particles retarded the grain growth and increased the hardness [8]. Karthikeyan and Mahdevan [10] studied the effects of SiC particle addition in the weld zone during FSW of AA6351 alloy. SiC particles were applied to the welding edges of the AA6351 alloy

plates prior to welding for introduction and incorporation of SiC particles in the weld region. The results indicated that the addition of SiC particles restricts the grain boundary growth by pinning and resulted in an increase in the mechanical properties to an extent of 33% in the as-welded condition over plain alloy.

In the present research, SiC particles were introduced at the weld interface of Friction Stir welded Mg alloy AZ31B in 4 different volume proportions of 10%, 15%, 25% and 30% to enhance the microstructure and mechanical properties. Metal Matrix composite reinforced by the SiC particles was formed in weld zone. The effect SiC particles on the mechanical and metallurgical properties of welded joints were investigated. The best volume proportion of SiC in enhancing Mechanical properties of welded joints was investigated. Microstructure and mechanical properties of unreinforced welded joints were compared with the SiC reinforced Friction stir welded joints.

Experimental Procedure of Magnesium Alloy AZ31B

The material used for friction stir welded butt joints with reinforcement were 4 mm thickness Magnesium Alloy AZ31B. The plate of Magnesium Alloy AZ31B was machined to required dimensions of 100 mm x 50 mm by using Shearing machine. The plates were machined on vertical milling machine at the edges of the plates in stepped shape, to form as a groove after placing their stepped ends in contact to fill the reinforced particles for different cases.

Before welding the plates were cleaned by using ethanol chemical to remove surface contaminations. The plates were fixed on vertical milling machine of HMT FM-2 having capacity of 10 H.P, 3000 R.P.M, for friction stir welding. The SiC particles were filled into a groove, as per different cases considered on the plate of 4-mm thickness before FSW was carried out. H13 Tool Steel was used as welding tool. The vertical milling machine was used to perform the welding process. The tool is placed in the tool holder of collect 18mm diameter. The initial welding has been done on the work pieces of 100 mm x 50 mm Magnesium Alloy AZ31B plates without reinforcement (Plates are un-stepped machined) by placing them on vertical milling machine which gets operated at rotational speed of 1400 R.P.M and feed of 25 mm/min. In the Second section, the 4 friction stir welds were performed to the Magnesium Alloy AZ31B steppedend plates by filling the Silicon Carbide (SiC) particulates as Reinforcement with 4 different volume praportions of 10%, 15%, 25% & 30% in the formed groove of plates after aligning their stepped faces in the fixed condition on the vertical milling machine which operates at rotational speed of 1400 R.P.M and feed of 25 mm/min. Temperatures were measured at different weld zones at different time & places along with the transverse and normal direction of weld line by using Infrared Thermometer, during the time of friction stir welding operation. Finally the welded plates were placed under Different Quality inspections of Non destructive and destructive. Radiography test and liquid penetrant tests were performed under non destructive tests. Destructive tests of Tensile test, Bend Test, Impact Test, and Rockwell Hardness Tests were performed. Metallurgical characterization was performed by taking microstructures on optical microscope.

To add the reinforcement particulates, the work pieces ends were machined on milling machine in the form of a step. The groove is formed at interface of two stepped ends of two plates as they are in Butt joint. Width and depth of groove decided according to volume percentage variation of reinforcement particulates. The Butt face of the job to be welded after filling reinforcement as shown in figure 1

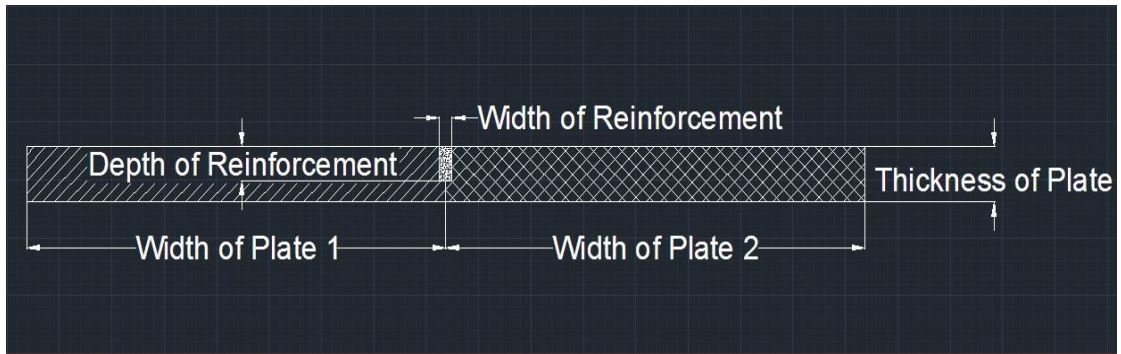

Figure 1: Schematic representation of workpieces with reinforcement groove

Chemical composition of Magnesium Alloy AZ31B

Table 1: Chemical Composition of Mg Alloy AZ31B

Element	Al	Zn	Mn	Cu	Si	Fe	Ni	Mg
Weight (%)	2.87	0.72	0.30	0.05	0.08	0.005	0.005	95.97

Tabulation of obtained different groove sizes for different volume proportions of reinforcement

Table 2: Different groove sizes for different Volume proportions of Reinforcement

Case	% of Reinforcement	Size of the Groove for Reinforcement	
		Width / Plate1 (mm)	Depth / Plate2 (mm)
I	10%	2	0.5
II	15%	3	0.5
III	25%	3	1
IV	30%	2.5	1

Friction stir welding of Magnesium Alloy AZ31B steppedend machined plates of 100 mm x 50 mm of 4 mm thick, which are under reinforcement condition with 10%,15%, 25%, 30% of Silicon Carbide at weld interface were butt welded at 1400 RPM rotational speed and 25 mm/min Transverse feed on Vertical milling machine.

Silicon Carbide of size 400 mesh was added as reinforce particulates at weld interface and Welded specimens were as shown in below figure 2.

Reinforced welded specimens

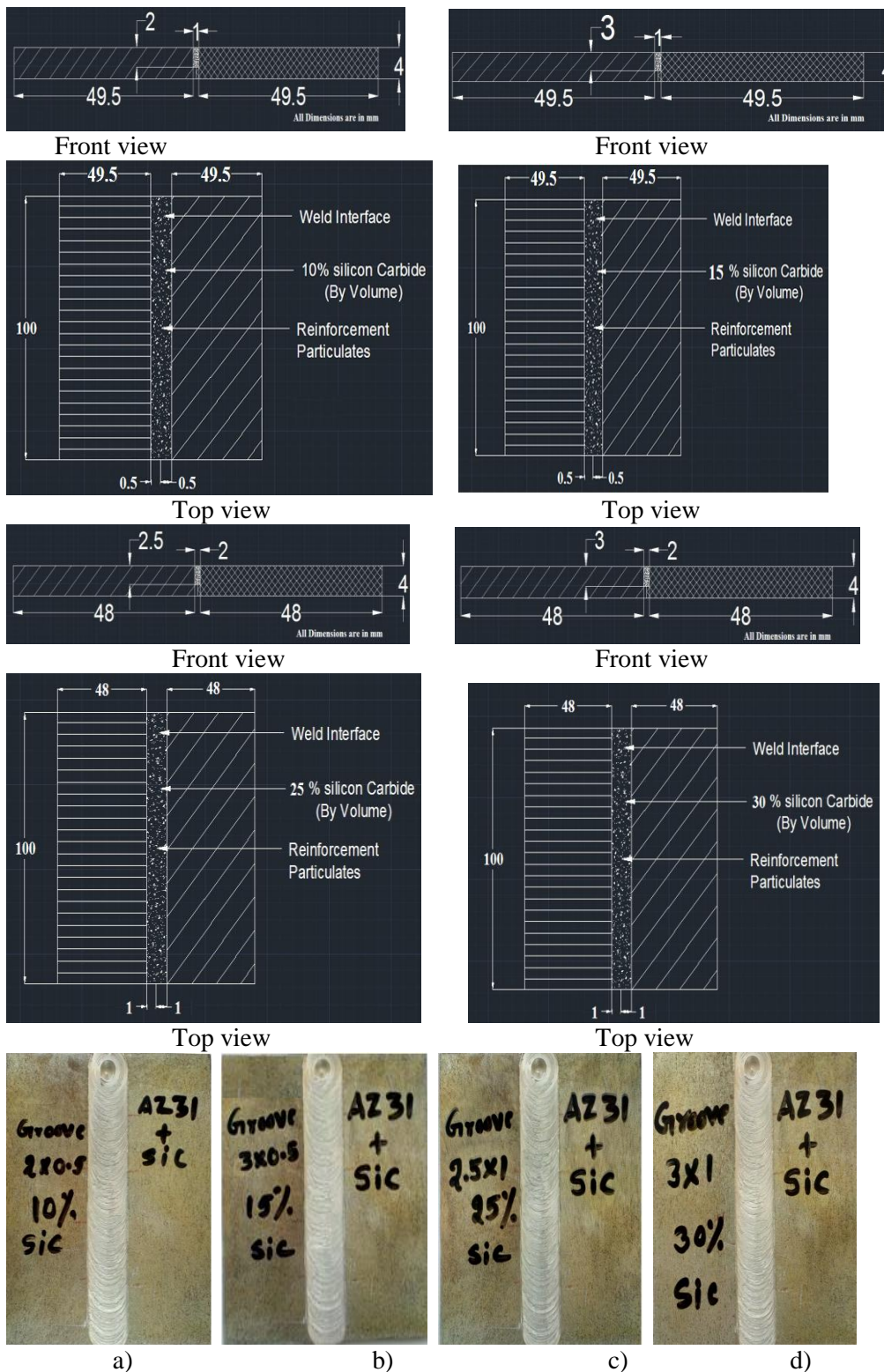

Figure 2: Reinforced FSJ joints of Mg alloy AZ31B a) 10% of sic b) 15% c) 25% d) 30%

Results and Discussion

Table 3: Mechanical properties of base material, un-reinforced and SiC reinforced friction stir welded joint of Mg Alloy AZ31B

Mechanical properties	Base material	un-reinforced FSWJ	% of Volume proportion of sic as reinforcement at friction stir weld interface of mg alloy az31b			
			10%	15%	25%	30%
U T S (MPa)	260.3	108	169.6	189.98	226.85	206
Yield Strength (MPa)	222.82	72	143.3	176.4	196.35	194
% Of Elongation (%)	15	5.5	6.9	7.1	8.2	7.8
Impact Strength (J)	4.5	3	4.3	4.8	5.7	5.7
Hardness (HRB)	44	49	51	56	62	65
Bend	0 ⁰	0 ⁰	0 ⁰	0 ⁰	0 ⁰	0 ⁰
C/S Area (mm ²)	50	50	50	50	50	50
Yield Load (KN)	11.14	3.6	7.16	8.82	9.81	9.7
Ultimate Load (KN)	13.01	5.4	8.48	9.39	11.34	10.3
Original Gauge Length (mm)	50	50	50	50	50	50
Final Gauge Length (mm)	57.5	52.75	53.45	53.55	54.1	53.9

Table 4: Comparison between Mechanical Properties of FSW Joint with Base Material

Comparison Between Mechanical Properties of FSW Joint with Base Material					
Mechanical properties	Un reinforced FSW joint	Reinforced friction stir welded joints			
		10% SiC	15% SiC	25% SiC	30% SiC
U T S (MPa)	58.05% Decreased	34.84% Decreased	27.01% Decreased	12.85% Decreased	20.86% Decreased
Yield Strength (MPa)	67.68% Decreased	35.68% Decreased	20.8% Decreased	11.87% Decreased	12.93% Decreased
% Of Elongation (%)	63.33% Decreased	54% Decreased	52.66% Decreased	45.33% Decreased	48.00% Decreased
Impact Strength (J)	33.33% Decreased	4.44% Decreased	6.66% Increased	26.66% Increased	26.66% Increased
Hardness (HRB)	11.36% Increased	15.90% Increased	27.27% Increased	40.0% Increased	47.2% Increased
Bend	No Change	NO Change	No Change	No Change	No Change

Table 5: Comparison between Mechanical Properties of Reinforced FSW Joint with Un-reinforced FSW joint

Mechanical properties	Comparison Between Mechanical Properties of Reinforced FSW Joint with Un-reinforced FSW joint			
	10% SiC	15% SiC	25% SiC	30% SiC
U T S (MPA)	57.03% Increased	75.90% Increased	110.04% Increased	90.7% Increased
Yield Strength (MPA)	99.02% Increased	145% Increased	172.7% Increased	169.44% Increased
% Of Elongation (%)	25.45% Increased	29.09% Increased	49.09% Increased	41.81% Increased
Impact Strength (J)	43.3% Increased	60% Increased	90% Increased	90% Increased
Hardness (HRB)	4.08% Increased	14.28% Increased	26.53% Increased	32.65% Increased
Bend	No Change	No Change	No Change	No Change

Comparison of Mechanical properties between base material, unreinforced and reinforced FSW of Mg Alloy AZ31B

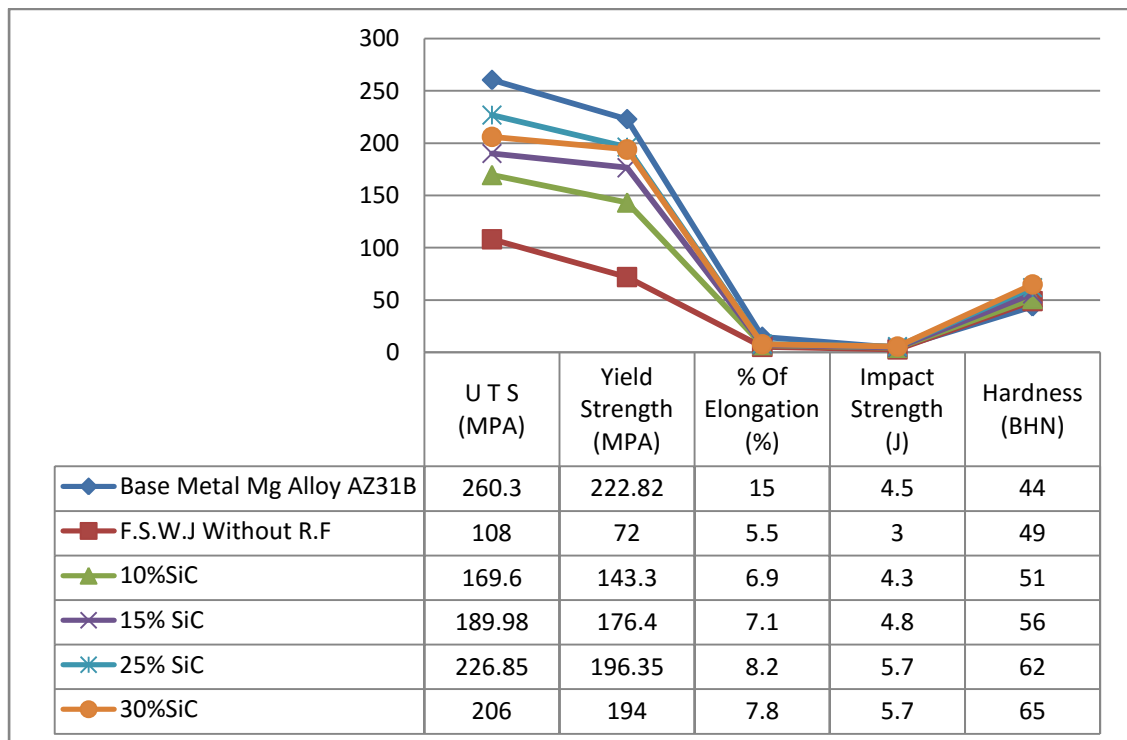

Fig 3: Comparison of Mechanical properties between base material, unreinforced and reinforced FSW of Mg Alloy AZ31B

Table 4 revealed that after friction stir welding of Magnesium Alloy AZ31B, Ultimate Tensile Strength of welded joint was decreased by 58.05%, Yield Strength of welded joint was decreased by 67.68% and Percentage of elongation was decreased by 63.33% over the base metal. Impact strength was decreased by 33.33%.

Hardness of friction stir welded joint of Mg Alloy AZ31B increased by 11.36% respectively over the base metal.

After addition of SiC particulates at weld interface, Mechanical properties of Friction stir welded joints of Mg alloy AZ31B were enhanced. Properties were enhanced with all four volume proportions of SiC. Maximum level of properties was obtained with 25% of volume proportion. Ultimate tensile strength, Yield strength, % of elongation was maximum level enhanced with 25% of volume proportion of SiC. Impact strength was maximum level enhanced and same at both 25% and 30% of volume proportion of SiC. Hardness was maximum level enhanced at 30% of volume proportion of SiC. Ultimate tensile strength, Yield strength, % of elongation are increased from 10 to 25% of volume proportion of SiC and then decreased from 25% to 30% of SiC. Hardness was increased from 10% to 30% of volume proportion of SiC. Impact strength was increased from 10% to 25% of SiC and maintained constant from 25% to 30% of SiC.

Microstructures

After successful joining, specimens of size 15 mm x 10 mm x 4 mm from both the sides of weld and from centre of the weld normal to the weld line were cut using a wire cut electric discharge machine (EDM) to study the metallurgical behavior at different regions of Stir zone (Nugget), Heat affected zone and parent metal. The specimens were then metallographically polished using different graded emery sheets of grid 80, 180, 220, 280, 320, 400, 600, 800, 1000, 1/0, 2/0, 3/0, 4/0 followed by polishing using diamond paste on disk polishing machine with red velvet cloth of 10" and cleaned with ethanol. Chemical etching of the polished specimens was done using 0.5% Hydrofluoric acid for 10 Seconds then rinsed distilled water and dried in hot air.

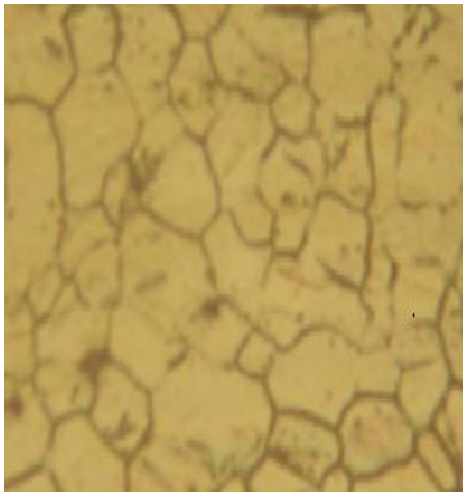

Figure 4: Microstructure of Mg Alloy AZ31B



Figure 5: Microstructure of Unreinforced FS Weld

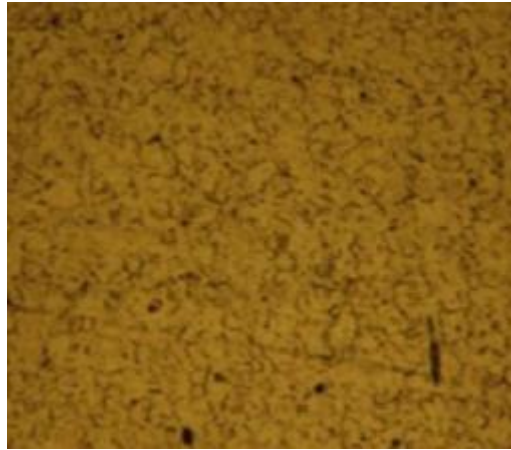

Figure 6: Microstructure of SiC Reinforced FS weld

The microstructure of the Friction Stir welded joint sample with added SiC particles in the weld region shows that the SiC particles are uniformly distributed in the nugget zone. It is also observed that the grain sizes in the nugget zone are refined due to recrystallization on account of stirring action which occurs during FSW process. The microstructures of the friction stir welded samples without and with the addition of SiC particles in the weld condition are shown in above Figures 5&6.

The grain size in the unreinforced friction stir welded joints is smaller than base material grain size due to the effects of dislocations which move and multiply during stirring and arrange themselves at high-angle boundaries, and consequently cell structure with small grain size is formed. It was observed that the grain size of SiC reinforced friction stir welds is smaller than the grain size of unreinforced friction stir welds. Due to refinement of grain size, the mechanical properties were enhanced in reinforced friction stir welds. Addition of SiC at weld interface stops the grain growth, so mechanical properties are enhancing of welded portion.

Conclusions

Friction Stir Welding of Magnesium Alloy AZ31B was successfully welded with and Without Reinforcement of Silicon Carbide. Mechanical Properties were enhanced due to addition of SiC particles as reinforcement at weld interface of friction stir welding of Mg Alloy AZ31B. Mechanical Properties were increased from 10% of SiC to 25% of SiC. But further increasing of Percentage of SiC i.e 25% to 30%, properties were decreased. 25% volume proportion of SiC was the best percentage of volume proportion in enhancing mechanical properties of friction stir welded joints of Mg Alloy AZ31B. Grain size of reinforced friction stir welded joints of Mg Alloy AZ31B is smaller than the unreinforced welded joints. Finally, FSW process, with SiC particles incorporated in the weld zone, is recommended to improve the mechanical properties of AZ31 magnesium alloy weld.

References:

- [1] H.Friedrich, L.Barry, Mordike (Eds.), “Magnesium Technology- Metallurgy, Design Data, Applications”, Materials, Springer, 2006.
- [2] Y. Morisada, H. Fujii, T. Nagaoka, and M. Fuukusumi, “Effect of Friction Stir Processing with SiC Particles on Microstructure and Hardness of AZ31”, Material Science Engineering A, v. 433, pp 50–54, 2006.
- [3] M.Abbasi, Abdollahzaden, B. Bagheri and H.Omidvar, “The effect of SiC particle addition during FSW on microstructure and mechanical properties of

- AZ31 magnesium alloy”, journal of materials engineering and performance, journal of materials engineering and performance, v.24, no. 12, pp 5037-5045, 2015.
- [4] W.B. Lee, J.W. Kim, Y.M. Yeon, and S.B. Jung, The Joint Characteristics of Friction Stir Welding AZ91D Magnesium Alloy, Material Transactions,v.44, no.5, pp 917–923, 2003.
- [5] Pradyumn Kumar Arya, “A Review on Friction Stir Welding for Aluminium Alloy Composite”, International Journal for Research in Applied Science & Engineering Technology, v.3, no.11, pp 324-332, 2015.
- [6] P. Karthikeyan and K. Mahadevan , “Investigation on the effects of SiC particle addition in the weld zone during friction stir welding of Al 6351 alloy”, The International Journal of Advanced Manufacturing Technology, v.80, no.9,pp1919-1926, 2015
- [7] Y.F. Sun and H. Fujii, “The Effect of SiC Particles on the Microstructure and Mechanical Properties of Friction Stir Welded Pure Copper Joints”, Material Science Engineering A, v.528, pp 5470–5475, 2011.
- [8] Y. Huang, T. Wang, W. Guo, L. Wan, and S. Lv, “Microstructure and Surface Mechanical Property of AZ31/SiC Surface Composite Fabricated by Direct Friction Stir Processing”, Materials Design, v.59, pp 274–278, 2014.
- [9] J. Guo, B.Y. Lee, C.N. Sun, G. Bi, and J. Wei, (2015), “Effect of Nano-Particle Addition on Grain Structure Evolution of Friction Stir Processed Al 6061 during Post-Weld Annealing”, TMS Annual Meeting & Exhibition, Orlando, USA.
- [10] P.Karthikeyan, and K.Mahadeven, “Evolution of Mechanical Properties of Friction Stir welds Al6351 Aluminium Alloy with reinforcement particles in the weld region”, Advanced Materials research, v.893, pp 361-364, 2014.